

This presentation of SWOT activities is
dedicated to Larry Hogue, W6OMF/sk
Who left the group on June 29, 2012

We will all miss you OM, thanks & 73



2 meters beyond Repeaters

Side Winders On Two Radio Club
thanks to: Art Jackson – KA5DWI

2 Meter Single Sideband Going Beyond the Line of Sight The Time is Right.

- ✱ Interested in taking on the challenges of 2-Meter Weak Signal operation?
- ✱ We are now in the bottom of the sunspot cycle.
- ✱ Upper HF band DX opportunities are far and few between.
- ✱ Many of the major Ham equipment manufacturers have developed full coverage HF to VHF transceivers.
- ✱ Many used All-Mode rigs for 2-Meters are available.

Background of the Weak-Signal Operator

- Tend to back into this part of the Ham radio hobby by pure accident
- Interest in Satellites
- Hearing DX on the local repeater
- C.B. SSB enthusiast
- 2 Meter SSB operation during Field Day
- Telecommunications background
- One VHF DX opening

Will everyone enjoy 2-Meter SSB? What kind of operator gets the most.

- 2-Meter SSB is not for everyone.
- If you expect activity like 20 Meters at the peak of the sunspot cycle... No
- You like studying propagation, to be at the right place at the right time... Yes
- Enjoy unique and special events...Yes
- The 2 Meter SSB specialist with limited resources must develop a general knowledge of physics, meteorology and astronomy in order to produce good results.
- The serious enthusiast can create their own opportunities with a top-notch Big-Gun station.
- The specialist can do a lot with a little.

Operating



- ✿ SSB Call frequency 144.200 MHz
- ✿ CW below 144.100 MHz
- ✿ EME (Non CW) 144.100 – 144.125 MHz
- ✿ Meteor Scatter WSJT 144.125 – 144.175 MHz (144.140 MHz random)
- ✿ PSK31 144.150 MHz
- ✿ General SSB Operating 144.175 – 144.275 MHz
- ✿ Nets 144.240 – 144.260 MHz (SWOT 144.250 MHz)
- ✿ Beacons 144.275 – 144.290 MHz

Popular Rigs

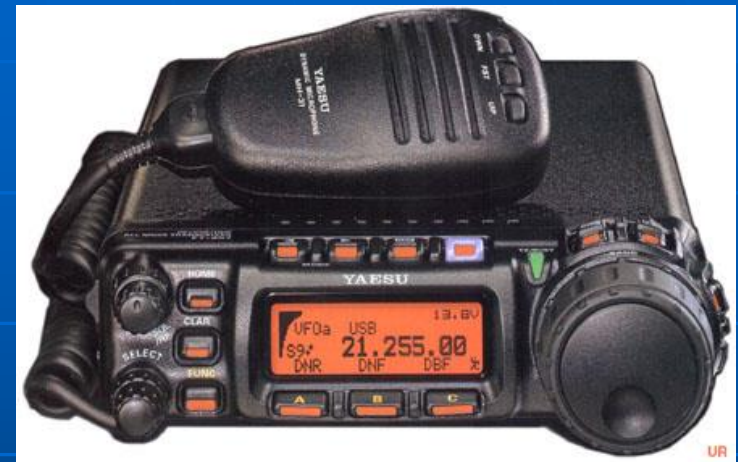

Older Rigs



Antennas - Simple



- Must be horizontally-polarized
- Squalo
- Halo
- Stacked arrays provide gain
- Best for mobile operations



Best Antennas

The Yagi

- Gain is everything
- Some is better than none.
- Some openings can be hurt by too much.
- Most openings are enhanced by more gain.
- The serious DX operator must have a high gained Yagi(s) to have good results.

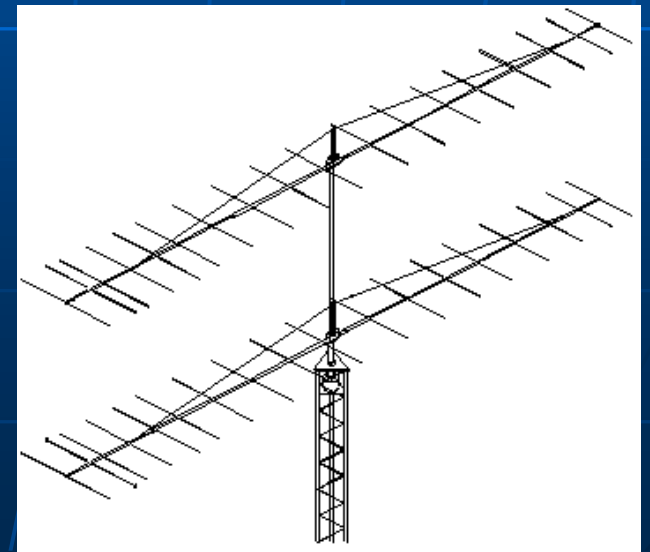
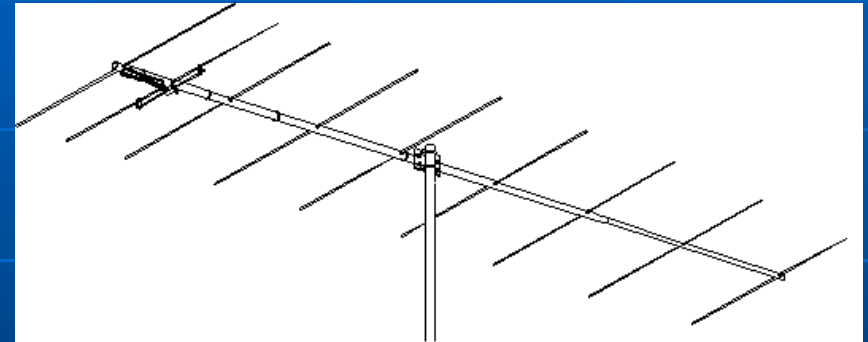

Peripherals



- Feed-lines.....
Low-Loss RG-8 such as LMR400, Belden 9913, RG-214 for short runs (< 100 ft.).
- Large runs –
Heliax and Hardlines
- Receive Preamps
- A decent power amplifier.

The 2-Meter Holy Grail

The Quest for "VUCC"

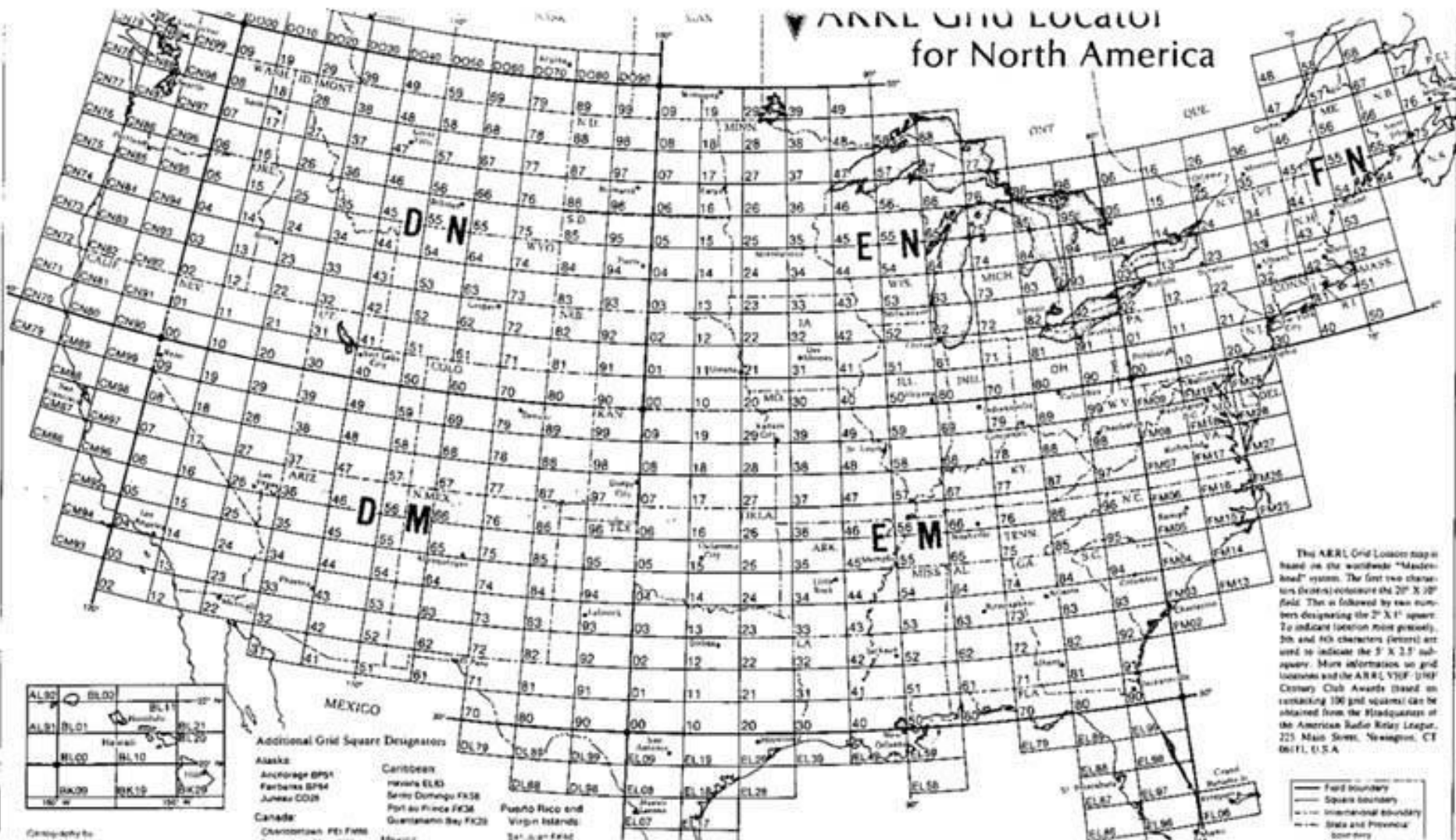

VUCC – VHF/UHF Century Club

Moderate achievement with moderate effort

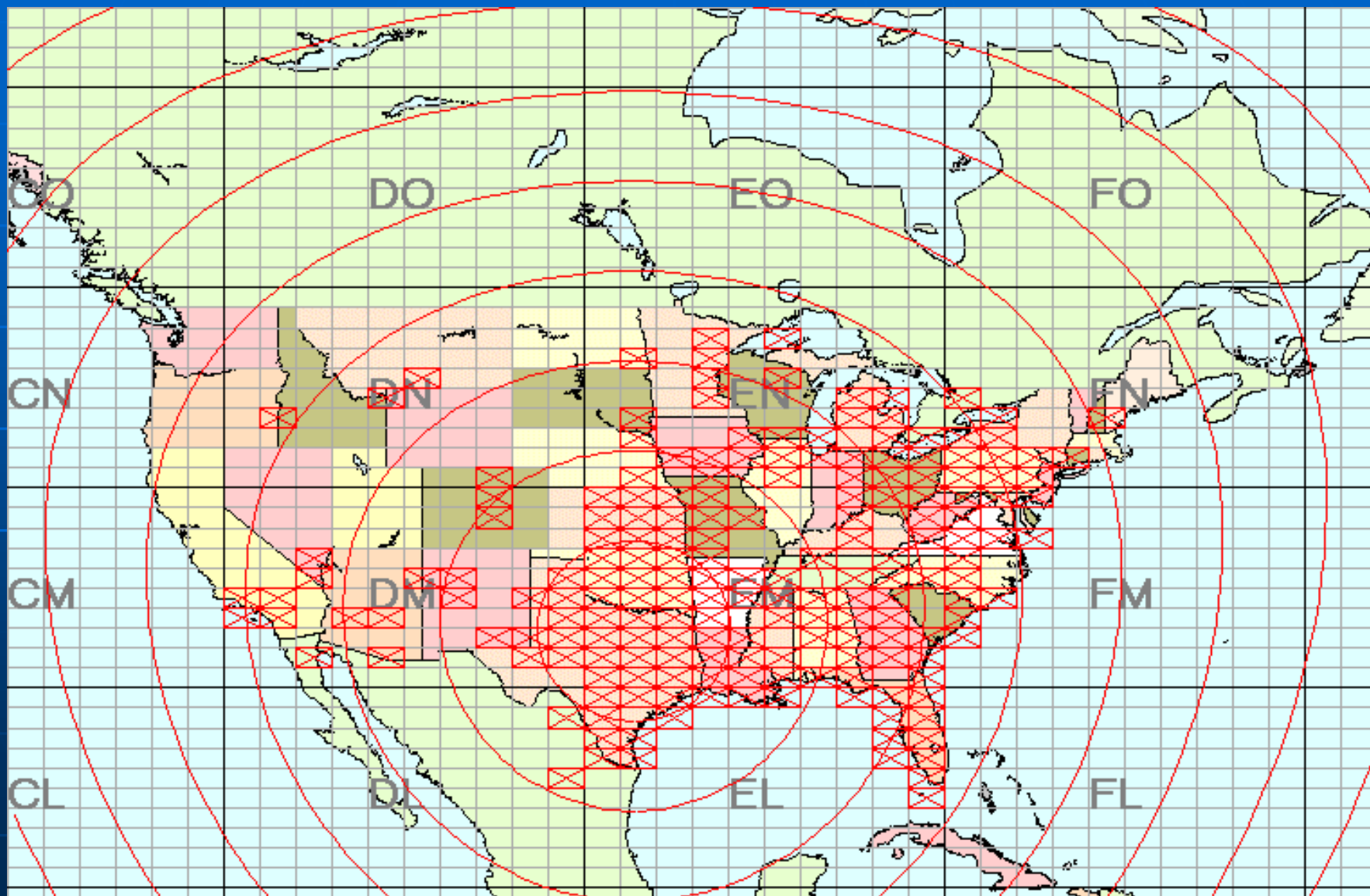

Propagation

What 2-Meter SSB/CW offers to the DXing community

- Earth-Moon-Earth (EME)
- Aurora
- Meteor Scatter
- Sporadic Es and FAI
- Tropospheric Ducting better known as Tropo.

Earth-Moon-Earth (EME)

Hyperlinks to:

[JT65 Signal output from Computer](#)



[OH7PI Barely above the noise floor](#)



- Due to the sheer difficulty and distance that the signal travels, it requires the best equipment and antennas.
- With a combination of several first-class stations and the development of the PC Soundcard digital modes, more simple set up stations are now completing their first QSOs on EME.
- WSJT is several digital modes developed by Nobel Prize winner Joe Taylor, K1JT. WSJT stands for "Weak Signal by K1JT".
- Earlier versions were developed into a mode called JT65. It is the standard for EME work
- Many of the better equipped stations still use CW, and on rare occasions SSB on EME.
- Overall, if you intend to regularly and successfully try EME, expect to make a serious financial commitment to equipment and construction of an antenna array.

WSJT 4 by K1JT

File Setup Mode Save Band Help

Az: SUN 300.76
El: -43.99

Az: MOON 102.78
El: -34.09
RA: 16:28
Dec: -27.26
LHA: -114.30
SD: 15.10

File ID Sync dB DT DF W DT (s) OH7PI_031122_104600 60

104600 6 -20 3.3 43 2 * K1JT OH7PI KP32

104600 1 1/1 K1JT OH7PI KP32

To radio: Grid (6-digit) Defaults
K1WHS FN43mi Sync 1 Zap
Clip 0 Freeze Custom
1594 mi 2565 km AFC
Az: 55 Tol: 400
BenStd Mms 2007 Mar 11
Auto is OFF 04:05:53 CQ KASDWI EM12
Dsec=0 Sync > 1 Clip=0 Tol=400

Recycle Bin User's Guide Desktop Ad-Aware SE
Notebook Maximizer Maple 10
Classic Worksh...
AvRack Maple Calculator
Buy at ToshibaDirect
Adobe Reader 7.0
WGLProp
Toshiba Access
Toshiba Console
Proprietary PSK
AT&T Yahoo! Online Pro...

start AT&T Yahoo! Mail... wsjt - AT&T Yahoo... Microsoft PowerP... 2 Meter Single Si... WSJT 4 by K1JT 11:05 PM

Aurora

Hyperlink to [K4QI 10/29/2003](#) 



- Aurora is a special propagation mode that is a result of the severe solar storms that are created by the Sun.
- During the entire Solar Cycle, sunspot regions form near adjacent Coronal Holes that often produce solar flares.
- Most of them are weak and are not pointed directly at the Earth.
- Every now and then, a major region facing the Earth produces a powerful flare. X-Class flares.
- The most powerful ones kill HF propagation.
- It is not the flare that produces Aurora, but it is the Coronal Mass Ejection (CME) that follows it that will create the magnetic disturbance one to two days later.
- The CME creates the strong Aurora Borealis that reflects 2 Meter signals. The stronger the magnetic disturbance, the further south it works.

Aurora

[Hyperlink to Mpeg of Extreme Solar Flare and CME 10/26-29 2003](#)

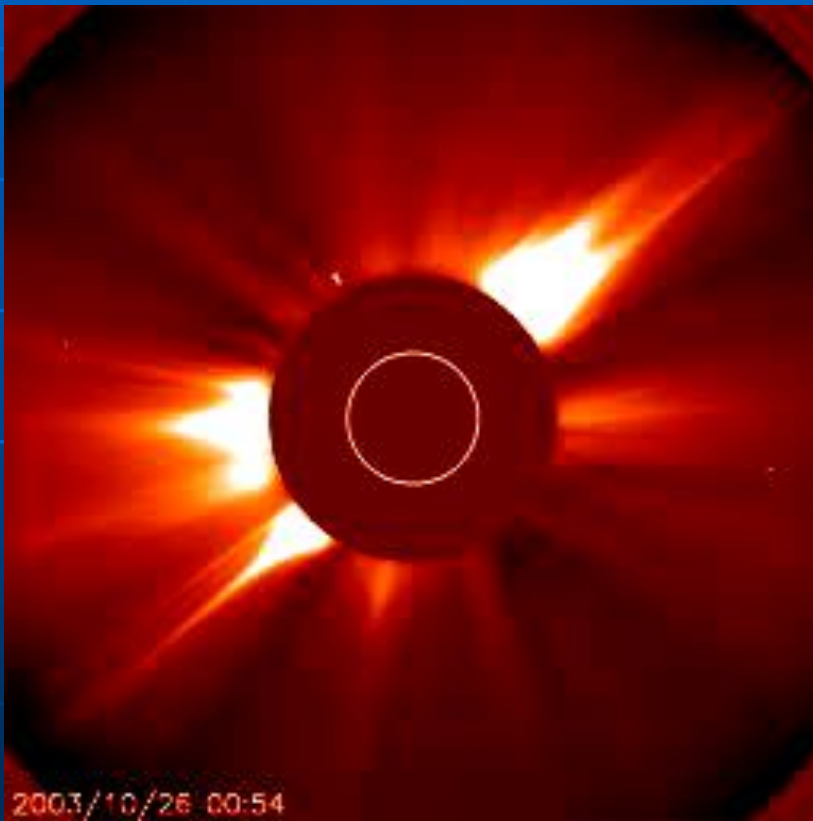

- Typically, only the northern most states experience it on a regular basis. The southern states do experience it around once every 2 to 3 years to once a year during solar cycle peaks.
- A good skill of CW is needed for Aurora. SSB contacts occur, but are rare overall.
- QSOs are the result of backscatter.
- Yagis are pointed NW to NE and signals sound raspy with a buzzing sound.
- Digital modes are ineffective.
- It requires high gain Yagi antennas with reasonable power (150 watts+), but has been completed with low power and low gained antennas.
- Florida, South Texas and Central California worked Aurora a little over 3 years ago.

Aurora – Internet Places to Watch

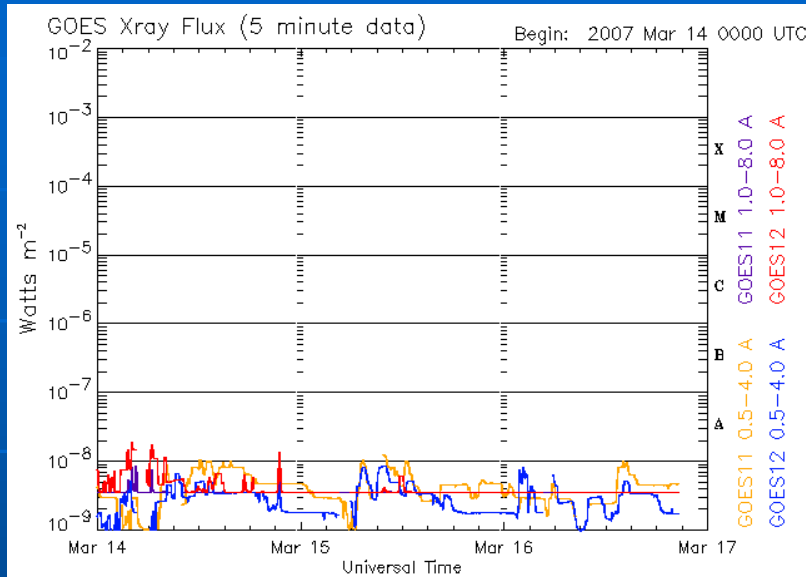

Updated 2007 Mar 16 20:41:05 UTC NOAA/SEC Boulder, CO USA

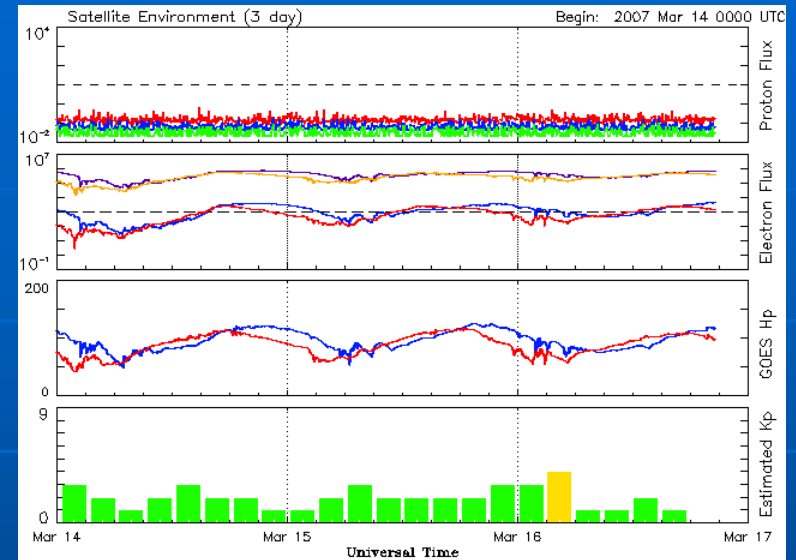

Updated 2007 Mar 16 20:41:15 UTC NOAA/SEC Boulder, CO USA

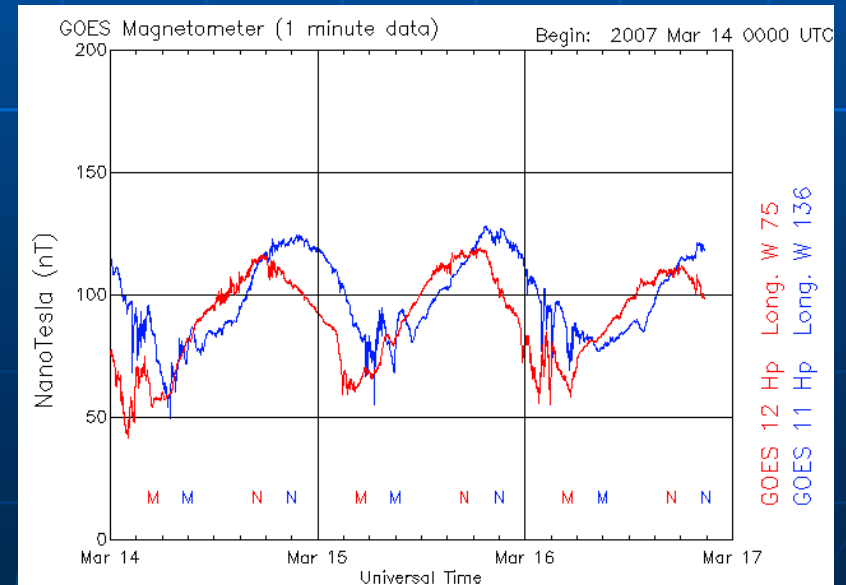
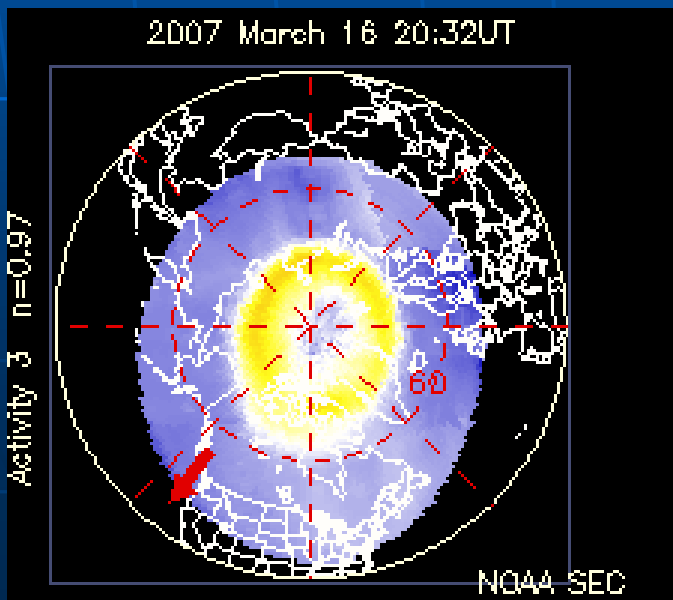

Updated 2007 Mar 16 20:45:10 UTC NOAA/SEC Boulder, CO USA

Meteor Scatter

Hyperlink for [K9MRI SSB Meteor Scatter during Leonids Storm](#)



- > Meteor Scatter was once considered a propagation mode to be used only during major annual meteor showers.
- > Usually once or twice in a lifetime does a Meteor Storm (as in November 2001 and 2002) provide one a continuous 2-Meter DX event.
- > Generally it required a pre-established schedule using timed transmissions between Ham radio operators.
- > Only at the meteor shower's peak, at a time period for the optimum direction for scatter, plus a lot of luck, did a non-coordinated CW or SSB contact work. Known as a random QSO.

Meteor Scatter

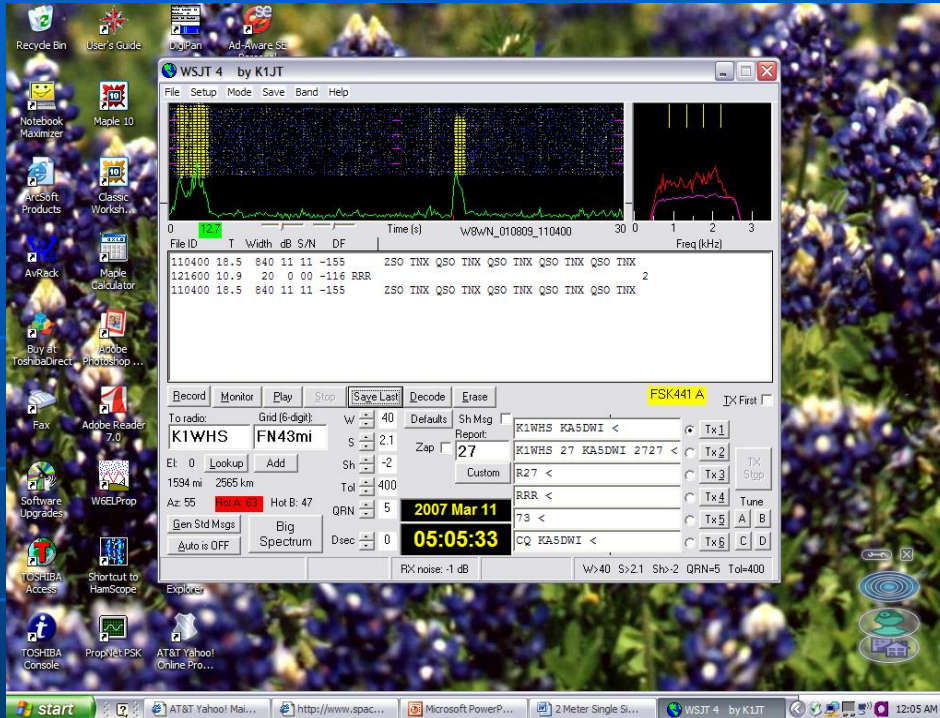

- The digital modes developed by K1JT's WSJT changed it all.
- Using the WSJT mode known as FSK441A, many are now completing random QSOs on 2 Meters.
- Scheduled QSOs are now being completed with ease during non-Meteor shower times.
- In the past few years, several Hams have accumulated over 40 states and nearly 300 Grid Squares (the pursuit of Grand VHF DX Award, VUCC) using the WSJT FSK441 digital mode.

Hyperlink to:
[FSK441A Transmission of "TNX QSO" during Perseids](#)



Ionospheric and Atmospheric conditions.

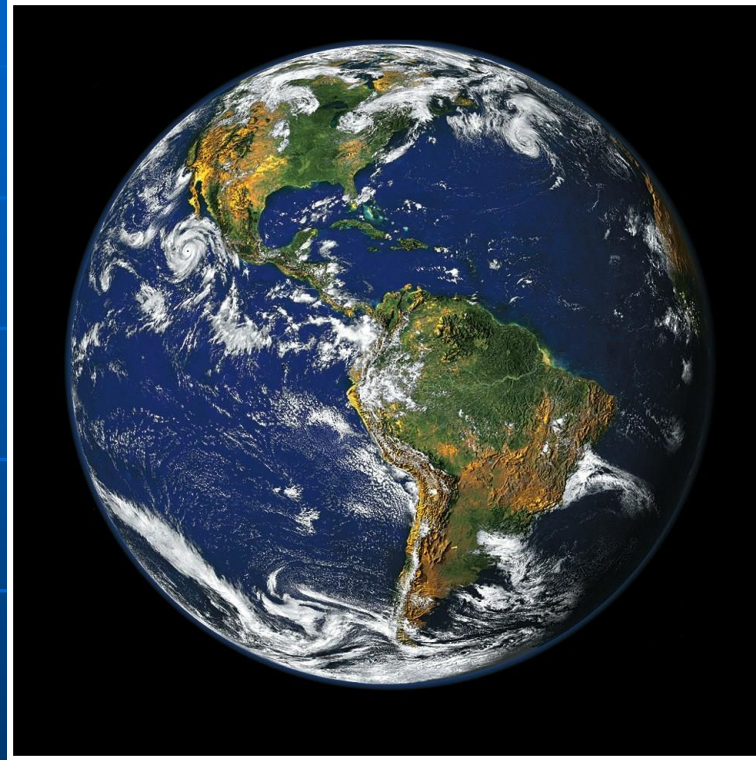

- Sporadic Es
- Tropospheric Ducting (Tropo)

Sporadic Es

Hyperlink to [K5UGM EM12 and KD4ESV EL87 Sporadic Es](#)



Lowell MA Digisonde
showing E layer
"curtain" reflections

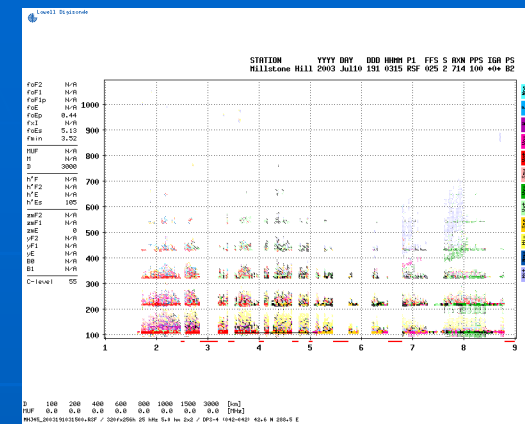

- ◆ Sporadic Es are commonly referred to as "Short Skip".
- ◆ Those who have operated 10-Meters, 11-Meters (CB) and 6-Meters, often make DX QSOs by using this propagation mode.
- ◆ When the Maximum Usable Frequency (MUF) for the E-layer of the ionosphere reaches 144 MHz, the docile and quiet 2-Meter band becomes a beehive of DX activity.
- ◆ The old saying that "you can work them with 5 watts and a wet noodle" is not that farfetched.
- ◆ This mode primarily occurs from the first week of May to the second week of August.
- ◆ A second season occurs from late November to late January, but is extremely rare if it reaches a 144MHz MUF, although it did this winter.

Sporadic Es



- The late Spring to mid-Summer season is when to concentrate on working Es.
- Using other tools, the Internet links, and software can prepare you for the opening.
- Most times Es propagation occurs first on lower frequencies (6 & 10 Meters), then intensifies before it becomes a 2-Meter opening.
- Monitoring TV channels 2 thru 7, the FM Broadcast band, and the Aircraft band will help one know where the optimum direction of the opening will occur.
- Most times a positive identification of a Channel 6 TV station (87.5MHZ) or a DX FM Broadcast station will be the direction of the eventual 2-Meter opening.
- If you hear the DX on your favorite 2-Meter repeater, you have been missing the opening for quite some time!!!! Hy

Sporadic Es



- ▶ Experienced Weak Signal enthusiasts listen for the increased noise levels associated with the band opening.
- ▶ Openings can vary in strength and length of time.
- ▶ It can be like Meteor Scatter or can close and open continuously for many hours.
- ▶ When intense, many QSOs occur with low power and simple antennas.
- ▶ Still, the high powered and sophisticated arrayed stations will have the greater results.
- ▶ Once every ten to eleven years, in any one given area will experience a "Super" opening. In 2004, the East coast experienced one such opening.
- ▶ In 1987, North Texas had a 2-Meter E opening simultaneously to both the East and West Coasts and a few QSOs were completed between the coasts (double-hop).
- ▶ It is becoming more common for the MUF to make it to 222 MHz, as a few more Hams are now active there.
- ▶ Once you have worked 2 Meter Es, you will be hooked. There is not anything more exciting and exhilarating in all of Ham radio.

Sporadic Es with FAI

Hyperlink to
[N6RMJ DM14 into Texas
on Es with FAI](#)

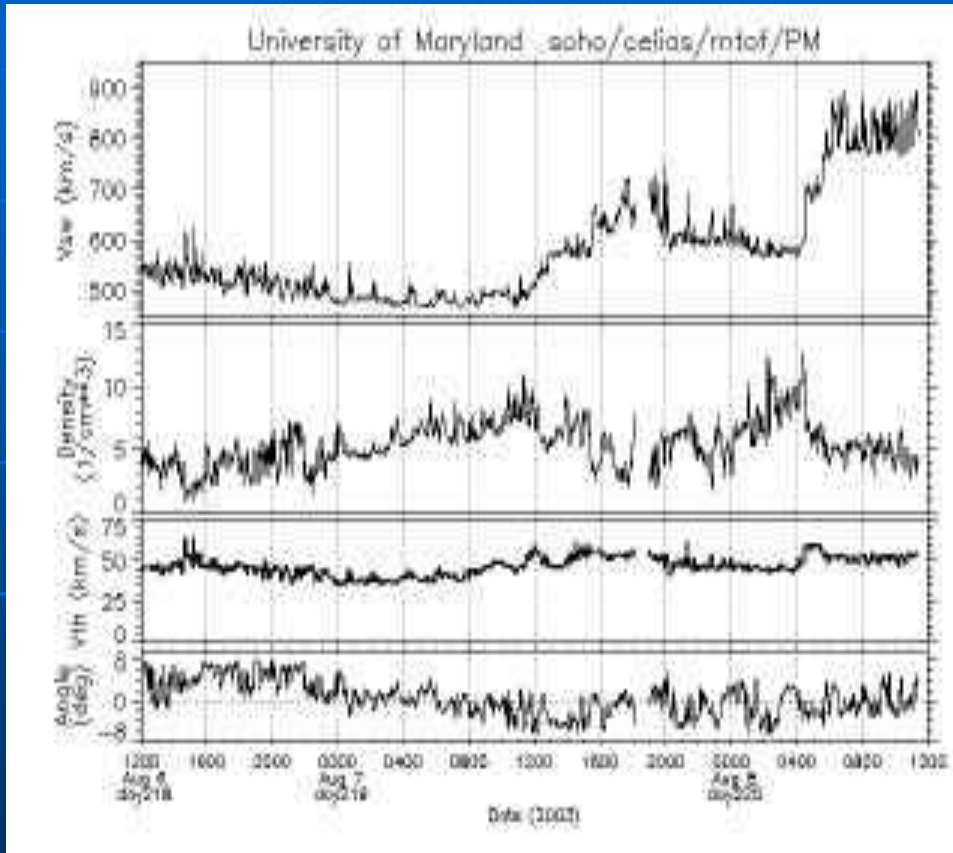

- Little is understood about FAI (Field Aligned Irregularities)
- It may be linked to Sporadic Es openings that are sparked by a solar disturbance.
- It tends to occur during an Es opening but the antennas are not pointed towards each other. It can be 90 degrees off.

SOHO Satellite Solar Wind Measurements

Tropo

- The most active DX propagation mode is Tropo.
- Tropo is the result of specific weather events.
- It is also the easiest of the DX modes to predict.
- As long as you can decipher weather maps that show surface and upper air pressure patterns, you can have an edge in working DX by being ready.
- The same tools used in operating Sporadic Es are available for Tropo, plus a few additional ones.
- Tropo is caused by one simple weather phenomena, significant (area and in height) temperature inversions.
- Tropo can occur at any time and place, but tends to favor early Spring to Mid-Fall.
- Close proximity to large bodies of water (Gulf of Mexico, Pacific and Atlantic Ocean, and Great Lakes) help and influence it, but is not always required.
- Monitoring VHF & UHF TV, FM Broadcast, the Internet links, and seeing large patches of “false echoes” on the National Weather Service Radars easily confirm these conditions.
- Major Tropo events require a stable atmosphere.
- Stormy weather only create localized and short events.

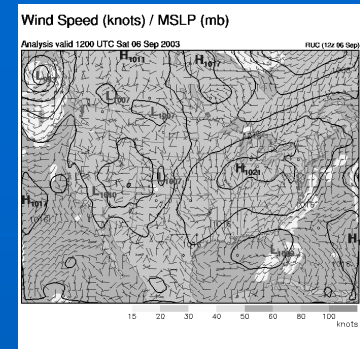

Tropo

Hyperlink to
[Tropo Opening between Tampa, FL and DFW, TX in the middle of the afternoon](#)

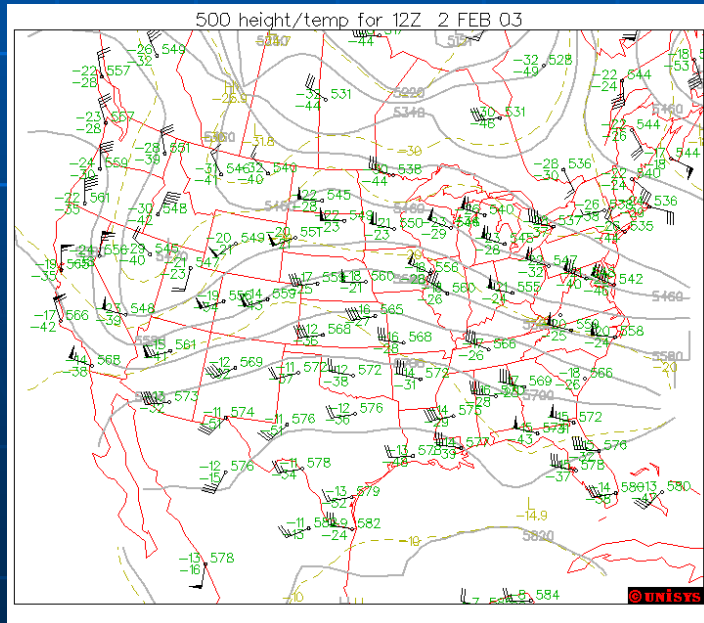
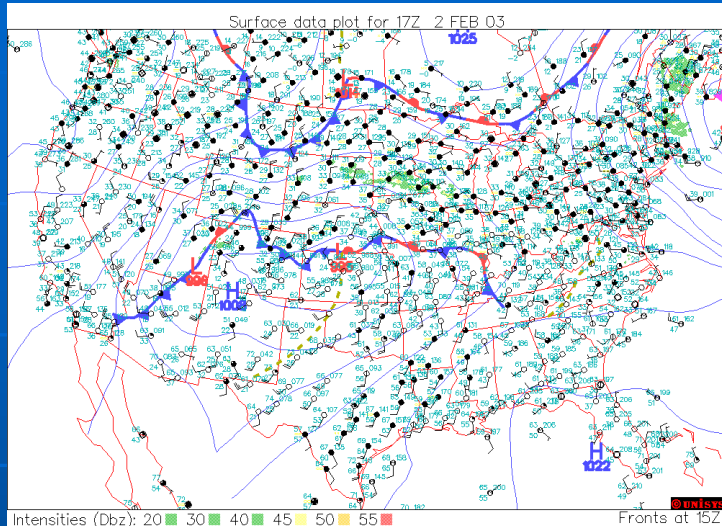

Surface and 500mb Maps

- Major events are directly caused by the strong influence of an Upper-Air High Pressure system (15,000-35,000 feet high) ridged over a surface High Pressure system.
- The area influenced occurs along the southwest, west and northwest areas of the surface and Upper Air High Pressure centers (the warm sides).
- A lack of upper air winds (indicating high pressure) helps cap the atmosphere.
- Temperate increases and the dew point decreases, resulting in a strong inversion to bend VHF and UHF signals.
- A hazy day, a warm foggy morning, heavy dew and a sudden increase in the daytime temperature from the day before are alerts to a possible Tropo condition.

Types of Tropo

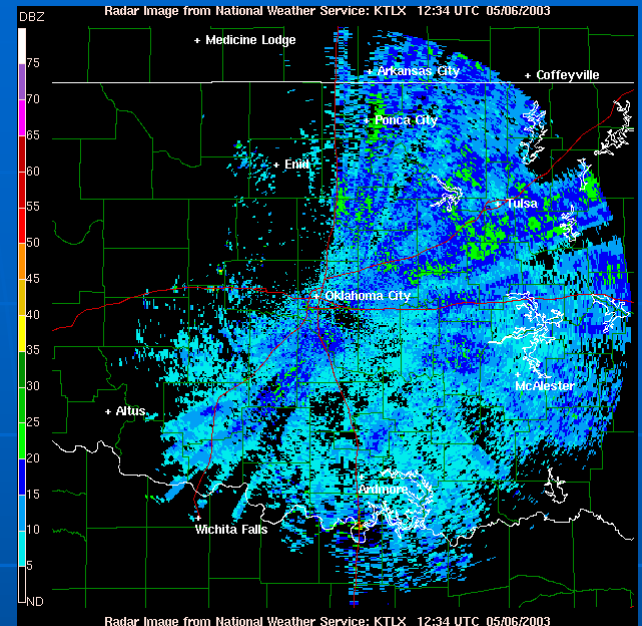

- **Line-of-Sight (GW)**
- **Tropospheric Scatter (TrS)**
- **Tropospheric Enhancement (TrE)**
- **Tropospheric Ducting (TrD)**

Confirming Tropo Conditions

Hyperlink to  Winter Late Evening Tropo Opening. AL & GA to TX Rare!!.

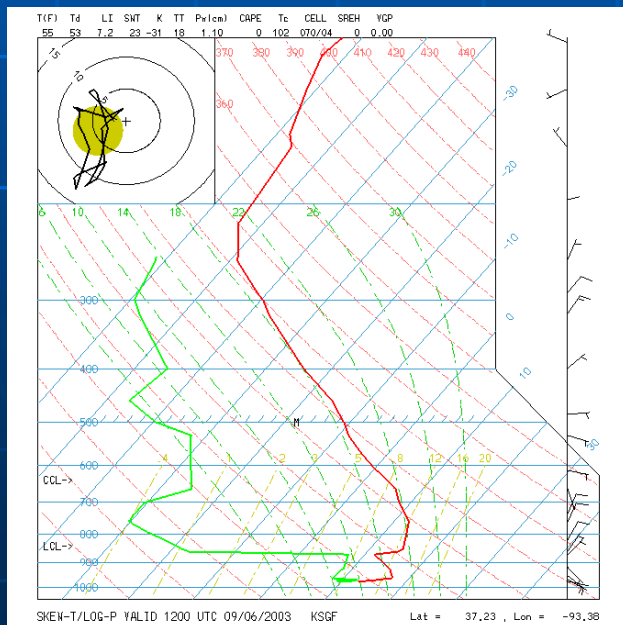
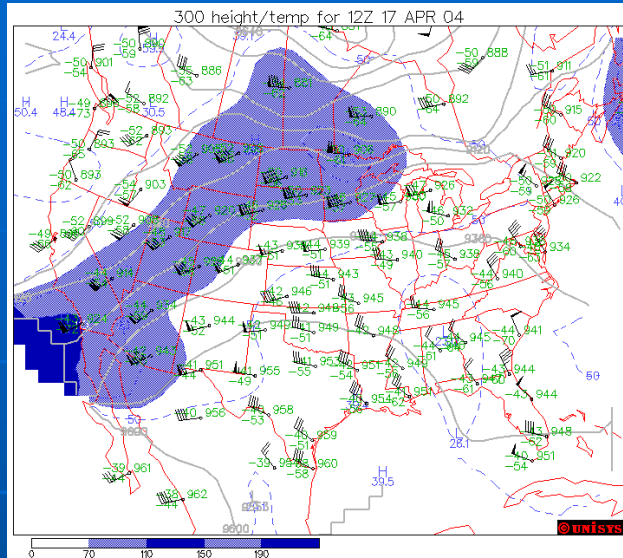

Massive "False Echoes"

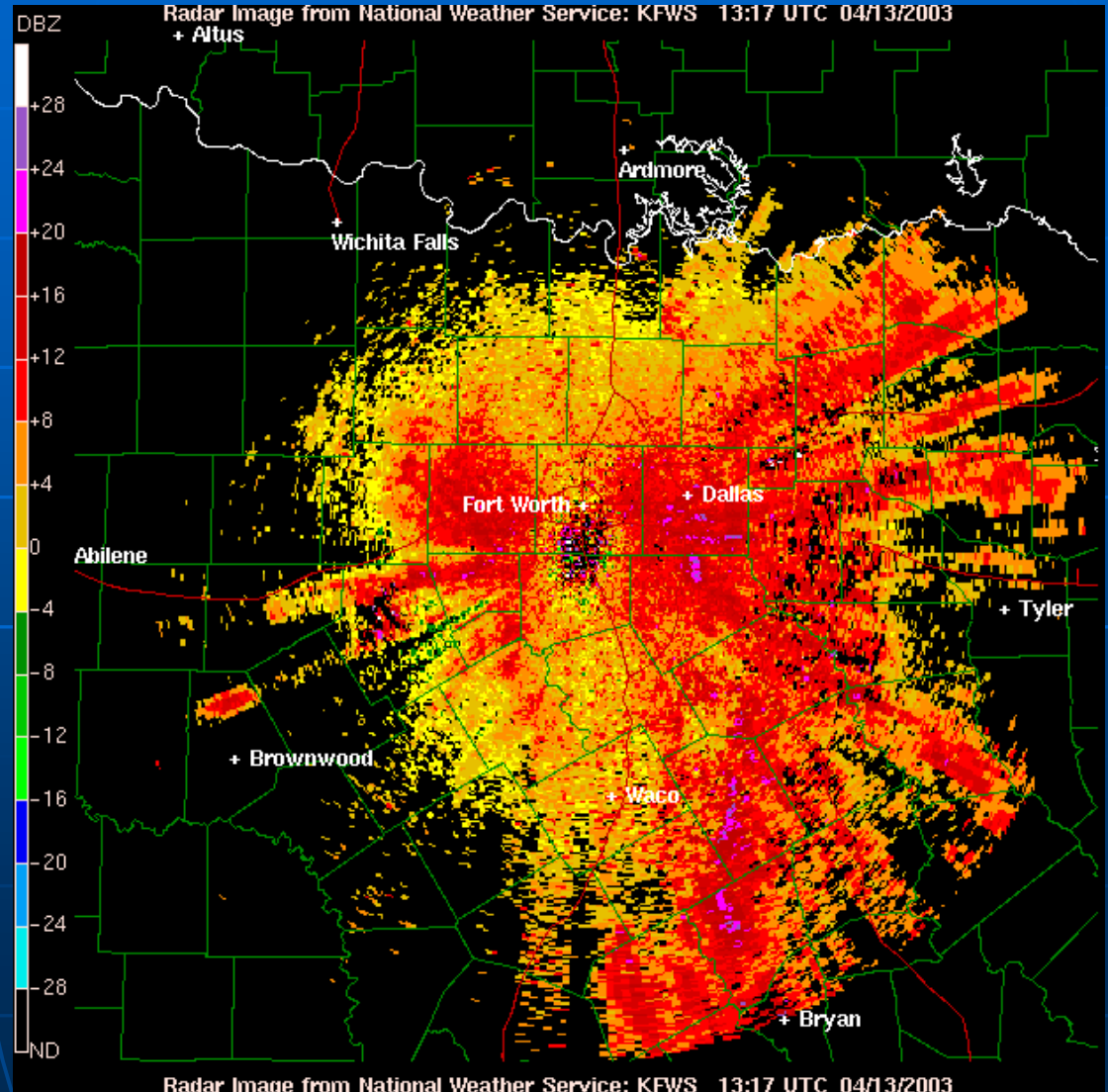

300mb and Upper Air Soundings

NWS Radars do not remove false echoes

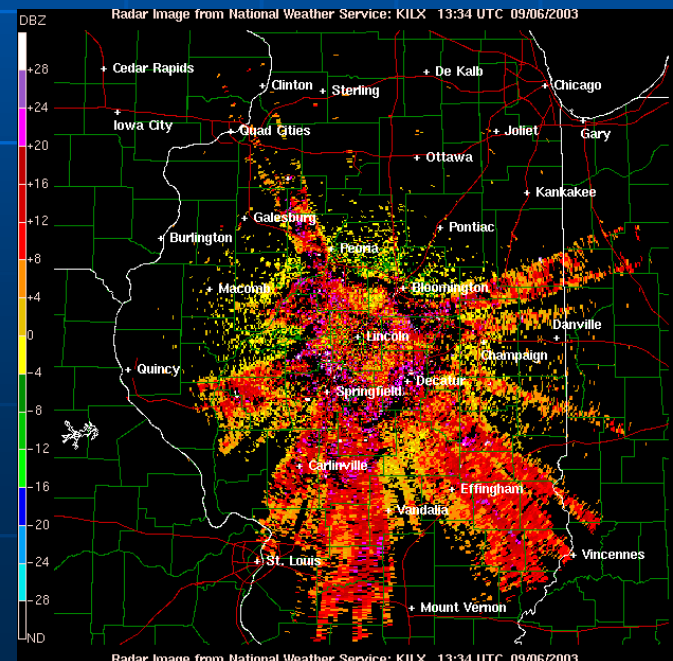
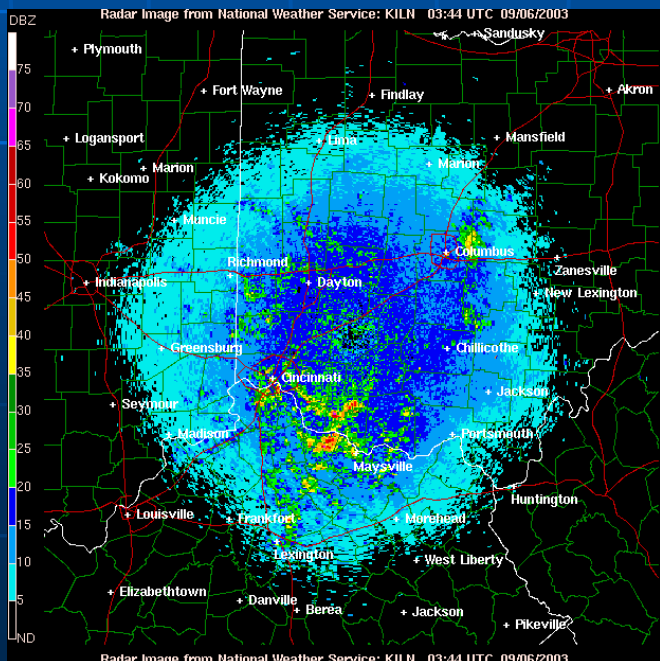
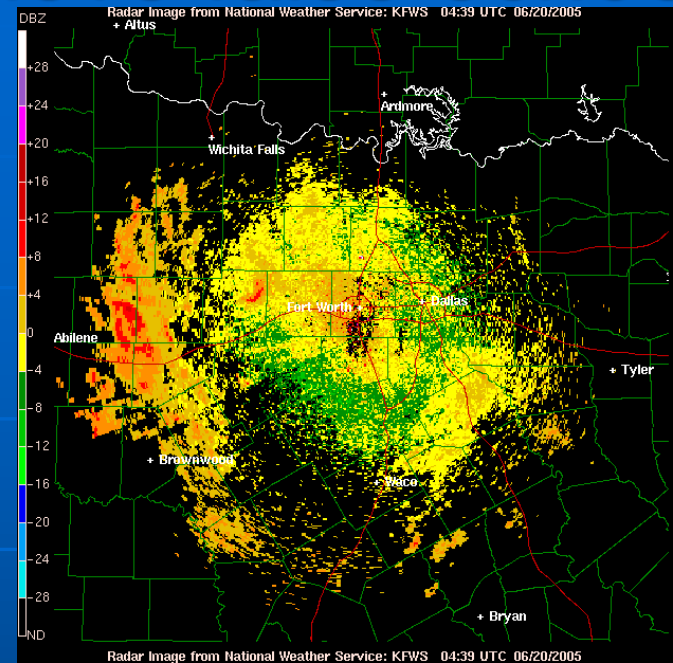
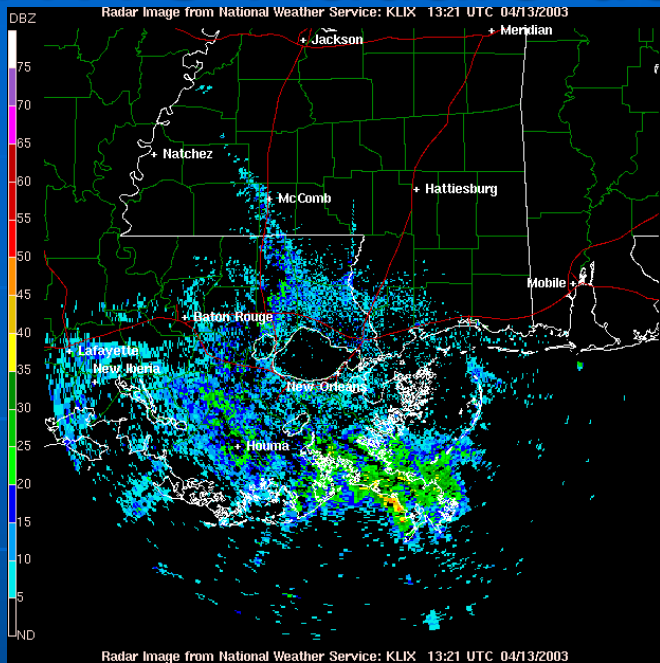

September 6-7, 2003

- The first Canadian based cold front followed by a strong surface high pressure system of the late summer/early fall moved through the eastern half of the United States.
- Once the front reached the Gulf of Mexico and the Atlantic Ocean, it stalled out just off shore.
- Meanwhile, a northward moving hurricane was situated between Bermuda and the U.S. East Coast.
- The hurricane had pushed the seasonal Bermuda High (the Upper Air one) well into the eastern half of the United States.

Wind Speed (knots) / MSLP (mb)

Analysis valid 1200 UTC Sat 06 Sep 2003

RUC (12z 06 Sep)

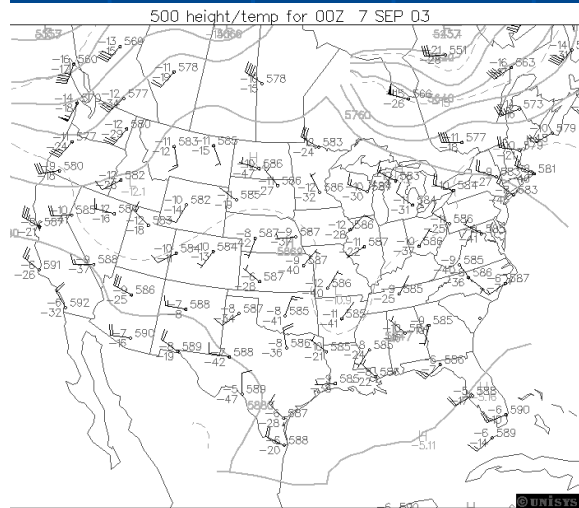
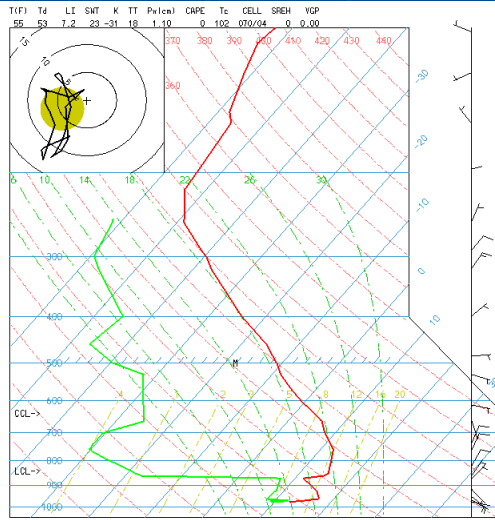
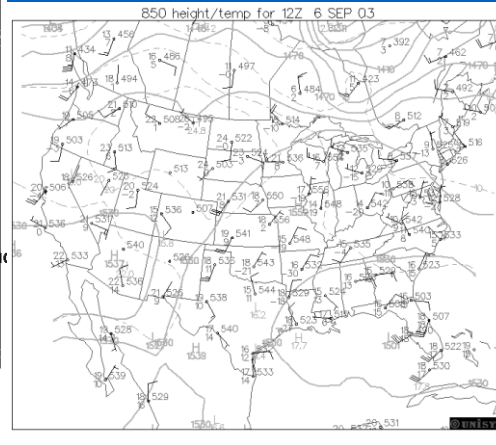
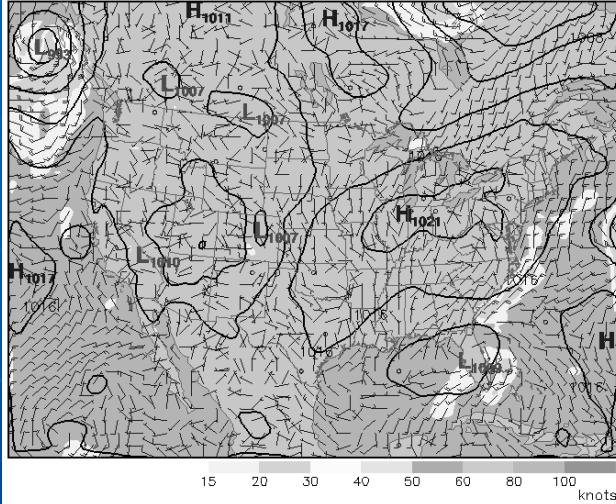

SKEW-T log-P VAL10 1200 UTC 09/06/2003 KSGF Lat = 37.23, Lon = -93.38

The Event

- The high pressure's western edge was located well into southern Texas to Nebraska and Iowa.
- Upper air winds in the eastern half of the U.S. were non-existent.
- For two evenings, successful SSB and CW QSOs were completed by many moderate to low powered Hams for distances just short of 1600 miles!
- A number of 30+ year old North American Tropo Continental DX records on 144 MHz and 222 MHz were broken.
- Most of the New England States completed QSOs with Texas, to Oklahoma, to Iowa on 2 Meter SSB.
- This was a once in a lifetime event.
- Still, many other long distance ones occur each year.

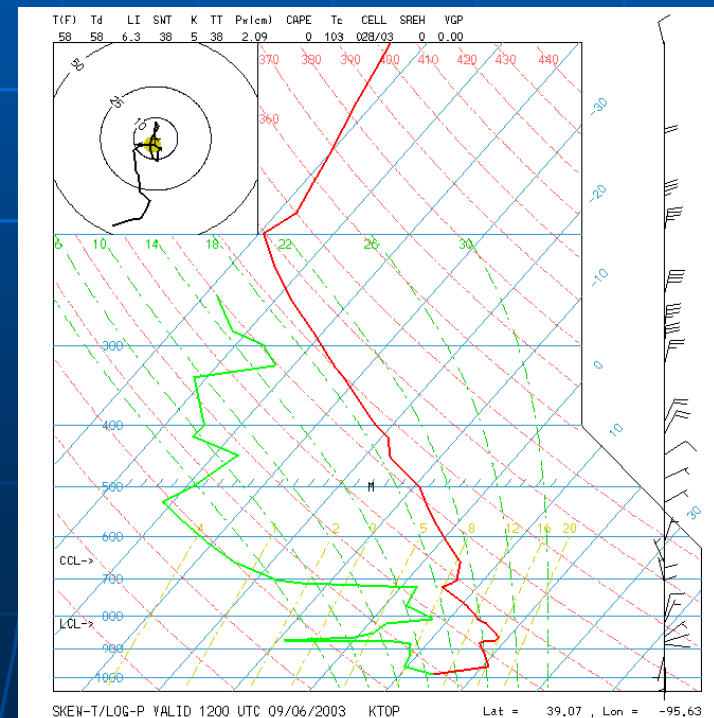
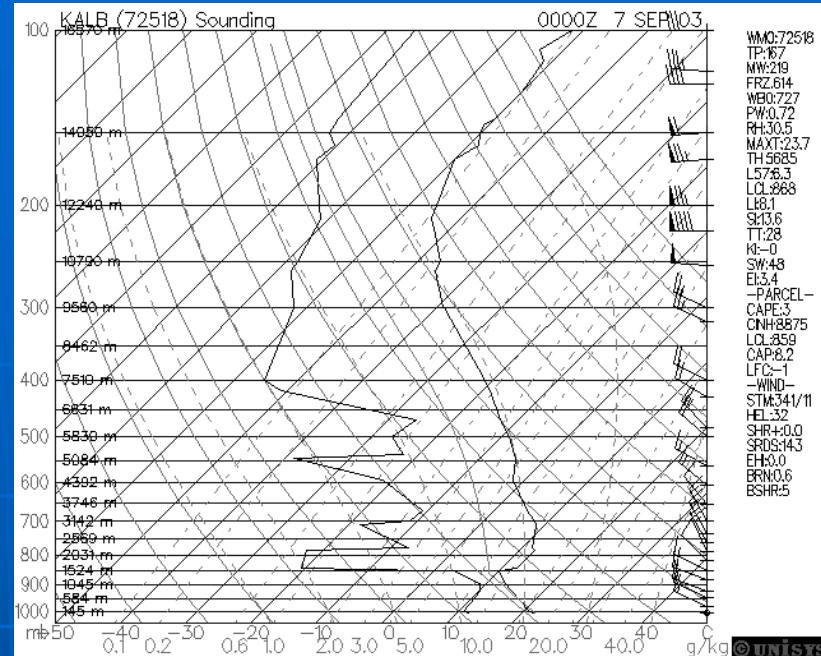

SWOT

- ◆ Who promotes 2-Meter Sideband?
- ◆ There are many fine VHF organizations, but only 1 radio club promotes it exclusively.
- ◆ That organization is the Side Winders On Two Radio Club, known as SWOT.
- ◆ The club was formed in the mid-1970's and has had nearly 3,500 register members over its history.
- ◆ Its roots started in North Texas, has members worldwide and a large Chapter in Northern California.
- ◆ SWOT promotes 2- Meter Sideband, CW and Digital operations and publishes a quarterly bulletin to inform and promote.





Side Winders on Two Radio Club S.W.O.T.

Promoting Weak Signal Operation since 1976



- You can find SWOT on the Worldwide Web at the SWOT Homepage: www.swotrc.net
- The SWOT Yahoo Group Page 427 strong: <http://groups.yahoo.com/group/sidewindersontwo/>
- Both Websites contain membership information, past Bulletins, DX Web links and audio examples of several major 2-Meter band openings.
- All are invited to visit, and we strongly urge you to join SWOT in order for us to share information with the Ham Radio community.
- Annual dues are only \$6 a year for an Emailed Bulletin.
- You will be issued a unique number (like 10-10, QRPARCI or SMIRK) and it is yours for life.

SWOT Nets



Day	LocalTime	Area	Net	Frequency	Net Control Station
SUN	8:00PM	VACAVILLE	NO. CALIFORNIA	144.250	W6OMF LARRY
	8:00PM	COSTA MESA	SO. CALIFORNIA	144.240	WB6NOA GORDON
MON	8:00PM	NE MISSOURI	NORTHEAST MISSOURI SWOT	144.250	N0PB PHIL
TUE	8:00PM	CA.NO CTYS	NORCAL	144.250	KG6WLV JOHN
WED	8:00PM	CENTRAL FL	DAYTONA BEACH SWOT	144.250	W1LVL George
					W2RAC Richard
	9:00PM	NO TEXAS	NORTH TEXAS SWOT	144.250	W5FKN BOB
THU	8:00PM	OK,TX,KS	EASTERN OKLAHOMA SWOT	144.250	KD5ZVE JIMMY
	8:00PM	CA SO CTYS	NORCAL	144.250	KA6CHJ PAUL
SAT	7:00AM	EAST TEXAS	PINEYWOODS SWOT	144.250	KM5PO JIM

- Look for one of our Nets and check in.
- As long as you are using a horizontally polarized Yagi and a reasonable power level, you should reach these Nets on most occasions. At least you can be usually relayed in.
- Our Nets are available to all, and you do not need to be a SWOT member.
- There has been discussions of the development of a PSK31 (SSB only) and CW Nets, but these have yet materialized. Interested in starting one of these? Let us know.

If you would like to join SWOT
Side Winders On Two
Northern California Chapter

contact Carl, WF6J after the meeting

Thank you for your interest



SIDE WINDERS ON TWO

RADIO

CLUB

S.W.O.T.